



REDUNDANCY MODULE

- Cost Effective Solution to Build Redundant Systems
- Dual Input with Single Output
- Two Diodes (Common Cathode)
- DC12-48V ± 25% (9-60Vdc) Wide-range Input
- Full Power Between -40°C and +60°C
- Width only 32mm
- Rugged Metal Housing
- Quick-connect Spring-clamp Terminals
- Easy Wiring:
Distribution Terminal for Negative Pole Included
- 3 Year Warranty

GENERAL DESCRIPTION

The YR2.DIODE is a redundancy module, which can be used to build 1+1 and N+1 redundant systems. It is equipped with two input channels which can be connected to 10A power supplies and one output which can carry nominal currents up to 20A.

The YR2.DIODE is the perfect solution to use in a redundant system, if the power supply itself is equipped with a DC-OK signal (e.g.: DIMENSION Q-Series). In addition to the YR2.DIODE is the YRM2.DIODE which has a monitoring circuitry included. LEDs and relay contacts signal when one of the two DC-input voltages is not in range due to a non-functioning power supply.

Another interesting application for this diode module is to separate sensitive loads from non-sensitive loads. This avoids the distortion of the power quality for the sensitive loads which can cause controller failures.

Unique quick-connect spring-clamp terminals allow a safe and fast installation and a large international approval package for a variety of applications makes this unit suitable for nearly every situation.

SHORT-FORM DATA

Input voltage	DC 12-48V	±25%
Input voltage range	9-60Vdc	
Input current	2x 0-10A 2x 0-16A	continuous for 5 seconds
Output current	0-20A 20-32A 25A	continuous for 5 seconds at cont. overload/ short circuit
Input to output voltage drop	typ. 0.78V typ. 0.85V typ. 0.85V	input: 2x5A input: 1x10A input: 2x10A
Power losses	typ. 0W typ. 7.8W typ. 8.5W typ. 17W	at no load input: 2x5A input: 1x10A input: 2x10A
Temperature range	-40°C to +70°C	operational, +60 to +70°C
Derating	0.5A/°C	
Dimensions	32x124x102mm	WxHxD

ORDER NUMBERS

Redundancy Module	YR2.Diode	12-48V Standard unit
Accessory	ZM1.WALL	Wall/panel mount bracket
	ZM11.SIDE	Side mount bracket

MARKINGS



INDEX

Page	Page
1. Intended Use3	16. Used Substances 11
2. Installation Requirements.....3	17. Physical Dimensions and Weight 12
3. Input and Output Characteristics4	18. Accessories 13
4. Power Losses.....5	19. Application Notes..... 14
5. Reliability6	19.1. Recommendations for Redundancy..... 14
6. Terminals and Wiring.....6	19.2. Inductive and Capacitive Loads..... 14
7. Functional Diagram.....7	19.3. Example: 1+1 Redundancy up to 10A..... 14
8. Front Side and User Elements.....7	19.4. Example: N+1 Redundancy up to 30A 15
9. EMC.....8	19.5. Example: Battery Back-up 15
10. Environment.....9	19.6. Example: Redundancy for Controls 16
11. Protection Features 10	19.7. Example: Decoupling of Branches 17
12. Safety Features 10	19.8. Use in a Tightly Sealed Enclosure 17
13. Dielectric Strength 10	19.9. Mounting Orientations 18
14. Approvals.....11	
15. Fulfilled Standards 11	

The information presented in this document is believed to be accurate and reliable and may change without notice. No part of this document may be reproduced or utilized in any form without permission in writing from the publisher.

TERMINOLOGY AND ABBREVIATIONS

PE and \oplus symbol	PE is the abbreviation for Protective Earth and has the same meaning as the symbol \oplus .
Earth, Ground	This document uses the term "earth" which is the same as the U.S. term "ground".
T.b.d.	To be defined, value or description will follow later.
DC 24V	A figure displayed with the AC or DC before the value represents a nominal voltage with standard tolerances (usually $\pm 15\%$) included. E.g.: DC 12V describes a 12V battery disregarding whether it is full (13.7V) or flat (10V)
24Vdc	A figure with the unit (Vdc) at the end is a momentary figure without any additional tolerances included.
may	A key word indicating flexibility of choice with no implied preference
shall	A key word indicating a mandatory requirement
should	A key word indicating flexibility of choice with a strongly preferred implementation
1+1 Redundancy	Use of two identical power supplies in parallel to provide continued operation following most failures in a single power supply. The two power supply outputs should be isolated each other by utilizing diodes or other switching arrangements. E.g. two 10A power supplies are needed to achieve a 10A redundant system.
N+1 Redundancy	Use of three or more identical power supplies in parallel to provide continued operation following most failures in a single power supply. All power supply outputs should be isolated each other by utilizing diodes or other switching arrangements. E.g.: To achieve a 40A redundant system, five 10A power supplies are needed in a N+1 redundant system.

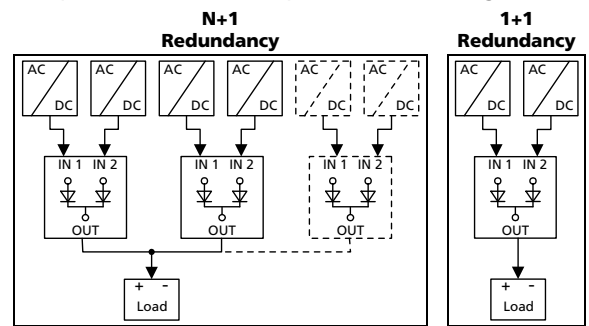

1. INTENDED USE

This device is designed for installation in an enclosure (according to the requirements of the end-standard) and is intended for the general use such as in industrial control, office, communication, and instrumentation equipment. Do not use this power supply in aircraft, trains and nuclear equipment where malfunction may cause severe personal injury or threaten human life.

2. INSTALLATION REQUIREMENTS

This device may only be installed and put into operation by qualified personnel.

This device does not contain serviceable parts.

If damage or malfunction should occur during installation or operation, immediately turn power off and send unit to the factory for inspection.

Mount the unit on a DIN-rail so that the input terminals are located on the top and the output terminals on the bottom of the unit. For other mounting orientations see de-rating requirements of chapter 19.9. in this document.

This device is designed for convection cooling and does not require an external fan. Do not obstruct airflow and do not cover the ventilation grid (e.g. cable conduits) by more than 30%!

Keep the following installation clearances:

40mm on top,

20mm on the bottom,

5mm on the left and right sides are recommended when the device is loaded permanently with more than 50% of the rated output current. Increase the side clearance to 15mm in case the adjacent device is a heat source (e.g. another power supply).

⚠ WARNING Risk of electrical shock, fire, personal injury or death.

- Turn power off before working on the device. Protect against inadvertent re-powering.
- Make sure that the wiring is correct by following all local and national codes.
- Do not open, modify or repair the unit.
- Use caution to prevent any foreign objects from entering the housing.
- Do not use in wet locations or in areas where moisture or condensation can be expected.
- Do not touch during power-on, and immediately after power-off. Hot surfaces may cause burns.

3. INPUT AND OUTPUT CHARACTERISTICS

Number of inputs	-	2	
Number of outputs	-	1	
Input voltage	nom.	DC 12-48V	±25% The input circuitry must meet the SELV requirements stipulated by IEC/EN/UL 60950-1.
Input voltage range	-	9-60Vdc	
Voltage drop, input to output	typ.	0.78V	at 2x5A, see Fig. 3-1
	typ.	0.85V	at 1x10A, see Fig. 3-2
	typ.	0.85V	at 2x10A, see Fig. 3-1
Input current	nom.	2x 0-10A	continuous
	nom.	1x 0-20A	continuous, see note 1
	nom.	2x 10-16A	for 5 seconds
Peak input current	max.	150A	for maximal 10ms per input
Output current	nom.	20A	continuous
	nom.	20-32A	for 5 seconds
	max.	25A	at continuous overload or short circuit, see note 2
Reverse current	max.	2mA	per input, -40°C to +60°C
Reverse voltage	max.	200Vdc	voltage applied to the output, continuously allowed

Note 1: Each input can be loaded up to 20A. At currents above 10A, the other input should not be loaded. It is preferable to parallel the two inputs in order to minimize the power loss in such cases.

Note 2: Ensure that the continuous output current does not exceed 25A. Check the short-circuit current of the power sources and if the power source can deliver more than 25A together, use an appropriate fuse on the output.

Fig. 3-1 **Input to output voltage drop when both inputs draw current**
(typical 1+1 redundant case, when the output voltages of the two units are equal or set into "parallel use" mode)

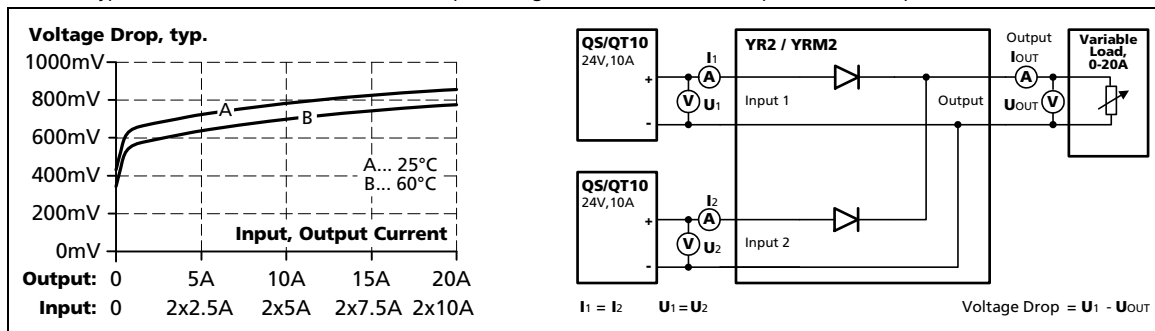
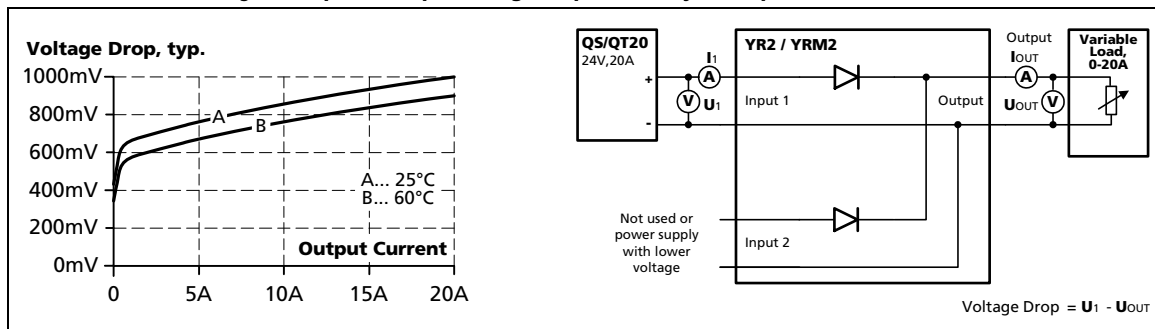

Fig. 3-2 **Input to output voltage drop when only one input draws current**



4. POWER LOSSES

DC 24V			
Power losses	typ.	7.8W	input: 2x5A
	typ.	8.5W	input: 1x10A
	typ.	17.0W	input: 2x10A
Standby power losses	typ.	0W	at no output current

Fig. 4-1 **Power losses**

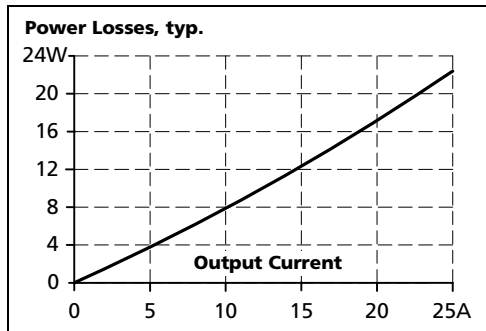

5. RELIABILITY

The redundancy module does not have electrolytic capacitors included. Therefore, the lifetime expectancy and MTBF value is extremely high.

Input / output current conditions		Input: 2x10A Output: 20A	Input: 2x5A Output: 10A	
Lifetime expectancy *)	min.	25 years	25 years	at 24V and 40°C
	min.	25 years	25 years	at 24V and 25°C
MTBF **) SN 29500, IEC 61709		46 500 000h	55 700 000h	at 24V 40°C
		70 000 000h	84 000 000h	at 24V 25°C
MTBF **) MIL HDBK 217F		36 200 000h	43 500 000h	at 24V and 40°C (Ground Benign GB40)
		41 100 000h	49 300 000h	at 24V and 25°C (Ground Benign GB25)

*) The **Lifetime expectancy** shown in the table indicates the minimum operating hours (service life) and is determined by the lifetime expectancy of the built-in electrolytic capacitors. Lifetime expectancy is specified in operational hours and is calculated according to the capacitor's manufacturer specification. The prediction model allows only a calculation of up to 15 years from date of shipment.
) **MTBF stands for **Mean Time Between Failure**, which is calculated according to statistical device failures, and indicates reliability of a device. It is the statistical representation of the likelihood of a unit to fail and does not necessarily represent the life of a product.

6. TERMINALS AND WIRING

	Input and output
Type	Bi-stable, quick-connect spring clamp terminals. IP20 Finger safe construction. Suitable for field- and factory installation. Shipped in open position.
Solid wire	0.5-6mm ²
Stranded wire	0.5-4mm ²
American Wire Gauge	20-10 AWG
Wire stripping length	10mm / 0.4inch
Pull-out force	10AWG:80N, 12AWG:60N, 14AWG:50N, 16AWG:40N (according to UL486E)

Instructions:

- a) The external circuitry of all terminals must meet the safety requirements stipulated by IEC/EN/UL 60950-1: SELV.
- b) Use appropriate copper cables that are designed for minimum operating temperatures of: 60°C for ambient up to 45°C and 75°C for ambient up to 60°C minimum.
- c) Follow national installation codes and installation regulations!
- d) Ensure that all strands of a stranded wire enter the terminal connection!
- e) Up to two stranded wires with the same cross section are permitted in one connection point.
- f) Ferrules are allowed, but not required.
- g) Do not connect or disconnect the wires from the terminals below -25°C (-13°F).

Fig. 6-1 **Connecting a wire**

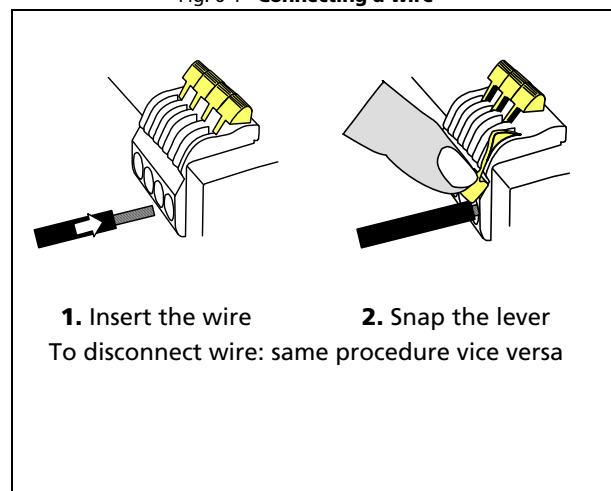

7. FUNCTIONAL DIAGRAM

Fig. 7-1 Functional diagram

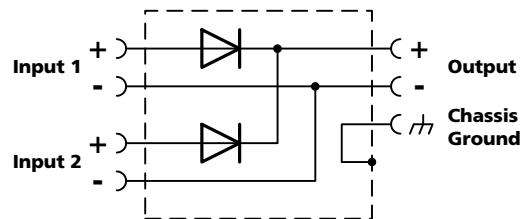

8. FRONT SIDE AND USER ELEMENTS

Fig. 8-1 Front side



A Output terminals

B Chassis ground terminal

Connection of the chassis is optional and not required since the unit fulfils the requirements according to protection class III.

C Input terminals for input 1

D Input terminals for input 2

9. EMC

This redundancy module is suitable for applications in industrial environment as well as in residential, commercial and light industry environment without any restrictions (e.g. cable length). The CE mark indicates conformance with EMC guideline 2004/108/EC and the low-voltage directive (LVD) 2006/95/EC. A detailed EMC report is available on request.

EMC Immunity	According generic standards: EN 61000-6-1 and EN 61000-6-2			
Electrostatic discharge	EN 61000-4-2	Contact discharge Air discharge	8kV 15kV	Criterion A Criterion A
Electromagnetic RF field	EN 61000-4-3	80MHz-2.7GHz	10V/m	Criterion A
Fast transients (Burst)	EN 61000-4-4	Input lines Output lines	2kV 2kV	Criterion A Criterion A
Surge voltage on input lines	EN 61000-4-5	+ → - +/- → Chassis ground	500V 1kV	Criterion A Criterion A
Surge voltage on output lines	EN 61000-4-5	+ → - +/- → Chassis ground	500V 1kV	Criterion A Criterion A
Conducted disturbance	EN 61000-4-6	0.15-80MHz	10V	Criterion A
Power-frequency magnetic field *)	EN 61000-4-8	50Hz	30A/m	Criterion A

Criteria:

A: Redundancy module shows normal operation behavior within the defined limits.

Notes:

*) A test is not applicable according to EN 50082-2, since the device does not contain components susceptible to magnetic fields, e.g. hall elements, electrodynamic microphones, etc.

EMC Emission	According generic standards: EN 61000-6-3 and EN 61000-6-4	
Conducted emission	IEC/CISPR 16-1-2, IEC/CISPR 16-2-1 IEC/CISPR 16-1-2, IEC/CISPR 16-2-1	Class B, input lines *) Class B, output lines *)
Radiated emission	EN 55011, EN 55022	Class B

This device complies with FCC Part 15 rules.

Operation is subjected to following two conditions: (1) this device may not cause harmful interference, and (2) this device must accept any interference received, including interference that may cause undesired operation.

*) Provided, that power sources connected on the inputs fulfill the class B requirements too.

10. ENVIRONMENT

Operational temperature *)	-40°C to +70°C (-40°F to 158°F)	Reduce output power above +60°C
Output de-rating	0.5A/°C	60-70°C (140°F to 158°F), see
Storage temperature	-40 to +85°C (-40°F to 185°F)	for storage and transportation
Humidity **)	5 to 95% r.H.	IEC 60068-2-30
Vibration sinusoidal	2-17.8Hz: ±1.6mm 17.8-500Hz: 1g 2 hours / axis	IEC 60068-2-6
Shock	30g 6ms, 20g 11ms 3 bumps / direction 18 bumps in total	IEC 60068-2-27
Altitude	0 to 2000m (0 to 6 560ft) 2000 to 6000m (6 560 to 20 000ft)	without any restrictions reduce output power or ambient temperature, see Fig. 10-2
Altitude de-rating	1.25A/1000m or 5°C/1000m	> 2000m (6500ft), see Fig. 10-2
Over-voltage category	not applicable	The concept of the overvoltage category is used for equipment energized directly from the low voltage mains (IEC 60664-1 §4.3.3.2.1).
Degree of pollution	2	IEC 62103, EN 50178, not conductive

*) Operational temperature is the same as the ambient temperature and is defined as the air temperature 2cm below the unit.

***) Do not energize while condensation is present

Fig. 10-1 **Output current vs. ambient temp.**

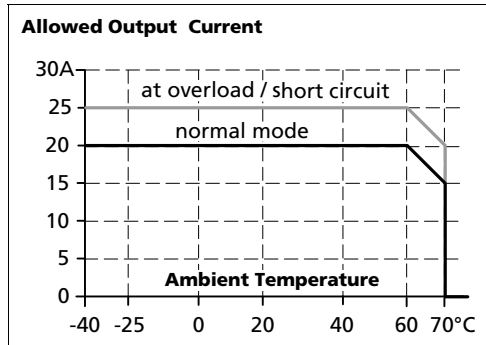
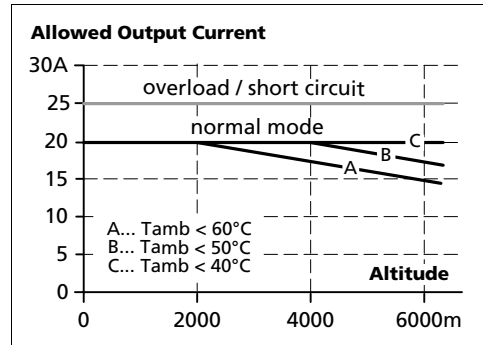

Fig. 10-2 **Output current vs. altitude**



11. PROTECTION FEATURES

Output over-current protection	not included	
Reverse input polarity protection	included	unit does not start when input voltage is reversed
Degree of protection	IP 20	EN/IEC 60529
Penetration protection	> 3.6mm	e.g. screws, small parts
Over-temperature protection	not included	
Input transient protection	not included	
Output transient protection	included	see EMC section
Internal input fuse	not included	

12. SAFETY FEATURES

Input / output separation	no galvanic separation	200V epitaxial diode between input and output
Safety level of output voltage	The output voltage is regarded to be SELV (EN 60950-1) or PELV (EN 60204-1, EN 50178, IEC 60364-4-41) if the input voltage fulfills the requirements for a SELV source or PELV source.	
Class of protection	III	PE (Protective Earth) or chassis connection not required
PE resistance	< 0.1Ohm	between housing and chassis-ground terminal

13. DIELECTRIC STRENGTH

The input and output voltages have the same reference, are floating and have no ohmic connection to ground. Type and factory tests are conducted by the manufacturer. Field tests may be conducted in the field using the appropriate test equipment which applies the voltage with a slow ramp (2s up and 2s down). Connect input/output terminals together before conducting the test.





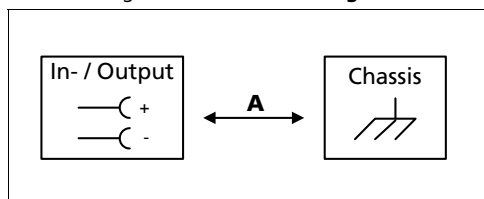

When testing, set the cut-off current settings to the value in the table below.

Fig. 13-1 Dielectric strength



	A	
Type test	60s	500Vac
Factory test	5s	500Vac
Field test	5s	500Vac
Cut-off current setting	> 2mA	

14. APPROVALS

IEC 60950-1		CB Scheme, Information Technology Equipment
UL 508		Listed for use as Industrial Control Equipment; U.S.A. (UL 508) and Canada (C22.2 No. 107-1-01); E-File: E198865
UL 60950-1		Recognized for use as Information Technology Equipment, Level 5; U.S.A. (UL 60950-1) and Canada (C22.2 No. 60950); E-File: E137006
CSA 22.2 No107.1-01		CSA approval for Canada CAN/CSA C22.2 No 107-1; CAN/ CSA 60950-1-03; UL60950-1
ANSI / ISA 12.12.01-2007 (Class I Div 2), pending		LISTED for use in Hazardous Location Class I Div 2 Tx Groups A,B,C,D systems; U.S.A. (ANSI / ISA 12.12.01-2007) and Canada (C22.2 No. 213-M1987) The unit is suitable for use in Class I Division 2 Groups A, B, C, D locations. Substitution of components may impair suitability for Class I Division 2 environment. Do not disconnect equipment unless power has been switched off. Wiring must be in accordance with Class I, Division 2 wiring methods of the National Electrical Code, NFPA 70, and in accordance with other local or national codes.
EN 60079-15 ATEX pending		Approval for use in hazardous locations Zone 2 Category 3G. Number of ATEX certificate: EPS 09 ATEX 1 236 The redundancy module must be built-in in an IP54 enclosure.
Marine		GL (Germanischer Lloyd) classified and ABS (American Bureau for Shipping) PDA Environmental category: C, EMC2 Marine and offshore applications

15. FULFILLED STANDARDS

EN/IEC 60204-1	Safety of Electrical Equipment of Machines
EN/IEC 61131-2	Programmable Controllers
EN 50178, IEC 62103	Electronic Equipment in Power Installations

16. USED SUBSTANCES

The unit does not release any silicone and is suitable for use in paint shops.

The unit conforms to the RoHS directive 2002/96/EC

Plastic housings and other molded plastic materials are free of halogens, wires and cables are not PVC insulated.

The production material within our production does not include following toxic chemicals:

Polychlorized Biphenyl (PCB), Polychlorized Terphenyl (PCT), Pentachlorophenol (PCP), Polychlorinated naphthalene (PCN), Polybrom Biphenyl (PBB), Polybrom Biphenyl-oxyd (PBO), polybrominated Diphenylether (PBDE), Polychlorinated Diphenylether (PCDE), Polydibromophenyl Oxyd (PBDO), Cadmium, Asbestos, Mercury, Silicia

17. PHYSICAL DIMENSIONS AND WEIGHT

Weight	290g / 0.64lb
DIN-Rail	Use 35mm DIN-rails according to EN 60715 or EN 50022 with a height of 7.5 or 15mm. The DIN-rail height must be added to the unit depth (102mm) to calculate the total required installation depth.
Installation clearances	See chapter 2

Fig. 17-1 **Front view**

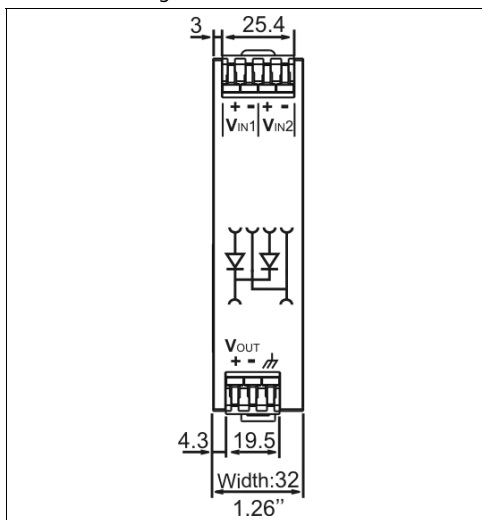
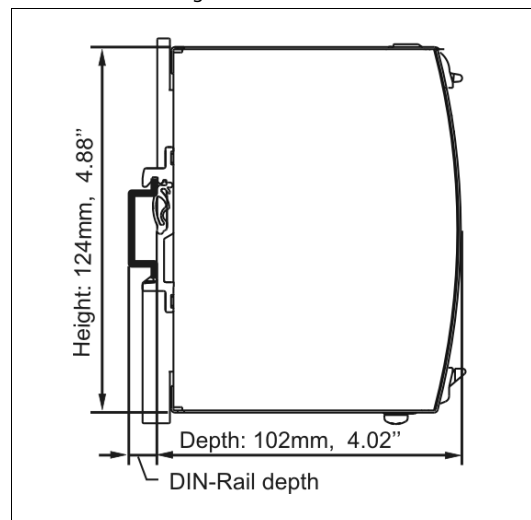

Fig. 17-2 **Side view**



18. ACCESSORIES

ZM1.WALL Wall mounting bracket

This standard bracket is used to mount the YR40 redundancy module onto a flat surface without utilizing a DIN-Rail.

Fig. 18-1 ZM1.WALL Wall mounting bracket

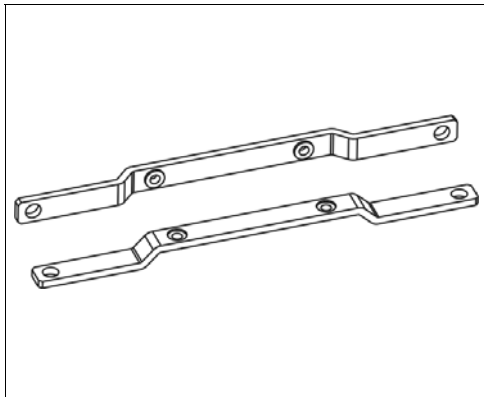
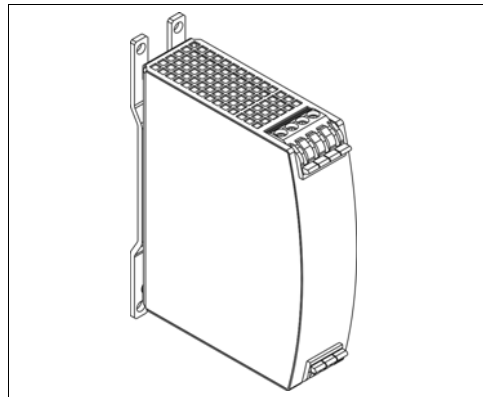

Fig. 18-2 Assembled wall mounting bracket



ZM11.SIDE Side mounting bracket

This bracket is used to mount the YR80 redundancy module sideways with or without utilizing a DIN-Rail.

The two aluminum brackets and the black plastic slider of the unit have to be detached, so that the steel brackets can be mounted.

For sideways DIN-rail mounting, the removed aluminum brackets and the black plastic slider need to be mounted on the steel bracket.

Fig. 18-3
ZM11.SIDE Side mounting bracket

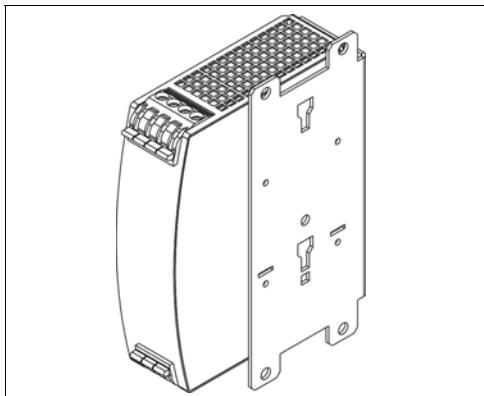
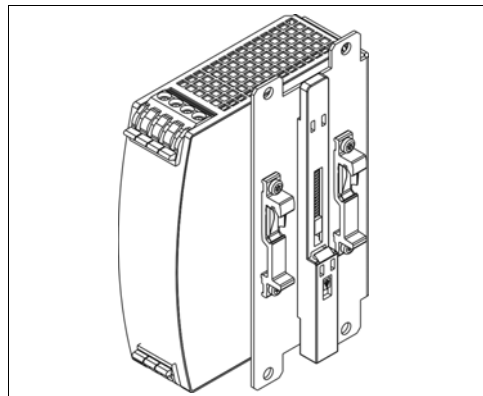

Fig. 18-4
Side mounting with DIN-rail brackets



19. APPLICATION NOTES

19.1. RECOMMENDATIONS FOR REDUNDANCY

Recommendations for the configuration of redundant power systems:

- Use separate input fuses for each power supply.
- Use three-phase power supplies to gain functional safety if one phase fails.
- When single-phase power supplies are utilized connect them to different phases or mains circuits if possible.
- Set the power supply in "Parallel-Use" mode if this feature is available
- It is desirable to set the output voltages of all power supplies to the same value.

19.2. INDUCTIVE AND CAPACITIVE LOADS

The unit is designed to supply any kind of loads, including unlimited capacitive and inductive loads.

19.3. EXAMPLE: 1+1 REDUNDANCY UP TO 10A

1+1 Redundancy up to 10A requires two 10A power supplies and one YR2.DIODE redundancy module.

Fig. 19-1 **Wiring diagram, 1+1 Redundancy, 10A output current**

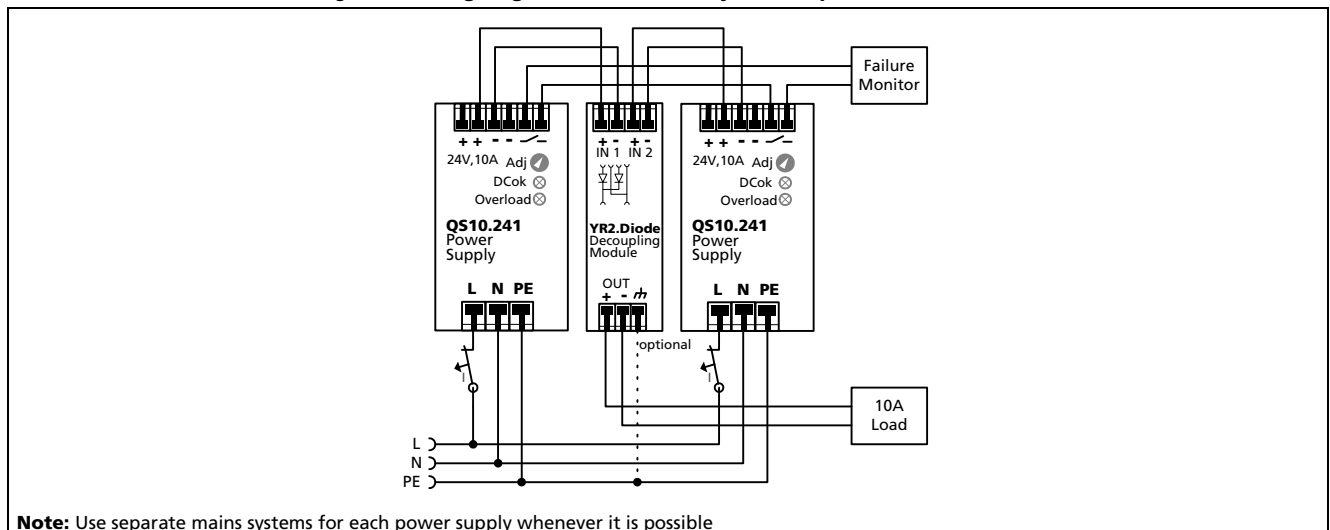

19.4. EXAMPLE: N+1 REDUNDANCY UP TO 30A

N+1 Redundancy up to 30A requires four 10A power supplies and two YR2.DIODE redundancy modules.

Fig. 19-2 **Wiring diagram, n+1 Redundancy, 30A output current**

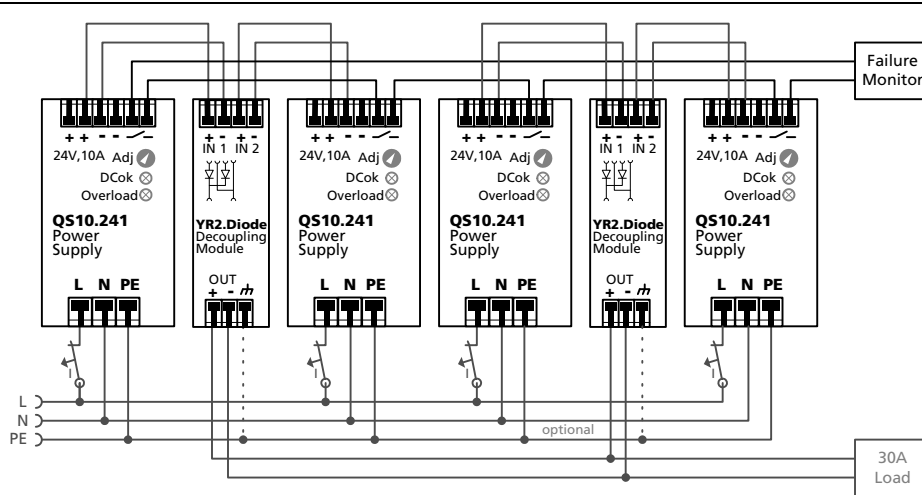

Note: Use separate mains systems for each power supply whenever it is possible

19.5. EXAMPLE: BATTERY BACK-UP

A battery back-up with 10A requires one 10A power supply and one YR2.DIODE decoupling module.

Please note:

Set output voltage of power supply to 26.5Vdc minimum to ensure, that the load current is delivered from the power supply and not from charger (battery). Use a fuse between battery and YR2.DIODE!

Fig. 19-3 **Wiring diagram, 10A Battery back-up**

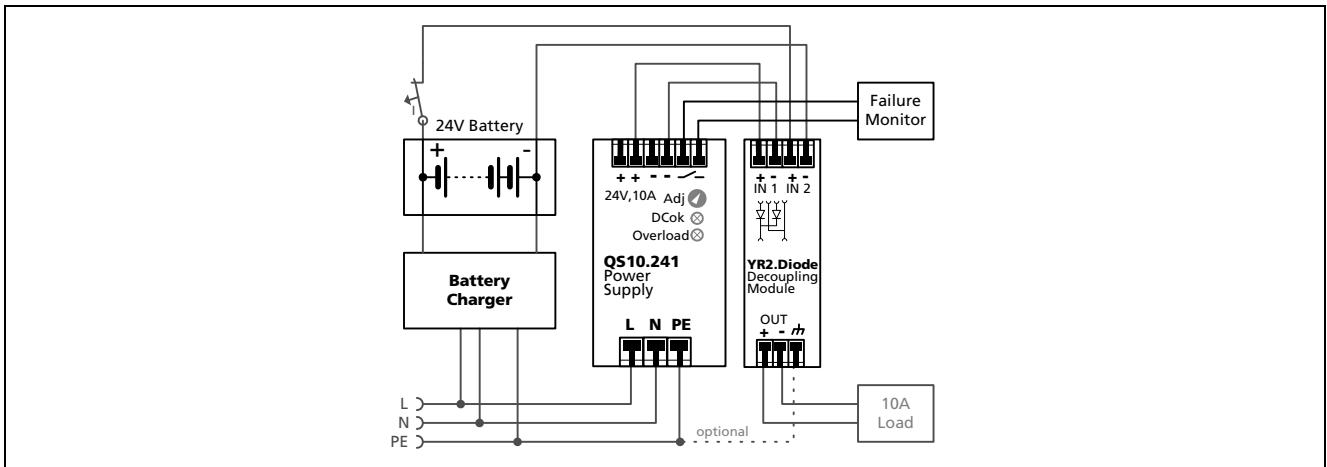

19.6. EXAMPLE: REDUNDANCY FOR CONTROLS

The diagram shows a cost effective solution to get redundant power for a PLC or controller system.

In many cases, two power supplies are used; one for the demanding loads and another one for the controls and sensitive loads. The power supply for the demanding loads can be used as a redundant source to supply the controls.

Traditional approach:

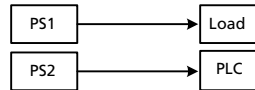

Improved approach:

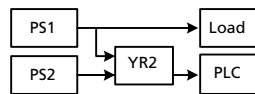
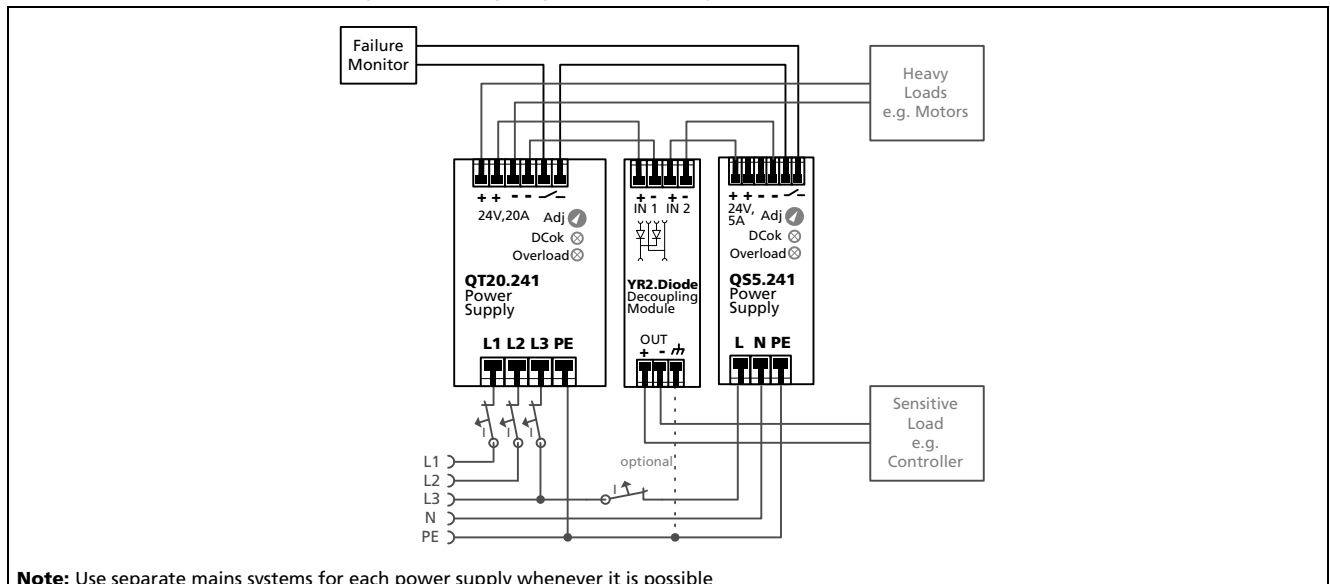

Fig. 19-4 Wiring diagram, redundancy for sensitive loads



Note: Use separate mains systems for each power supply whenever it is possible

19.7. EXAMPLE: DECOUPLING OF BRANCHES

Buffer energy supplied from a DC-UPS or buffer module is not wasted in "power branches".

Please note:

Set output voltage of the power supply to a level that the buffer unit or DC-UPS will not start unexpectedly. Take the voltage drop of the YR2.DIODE into account.

Fig. 19-5 **Wiring diagram, decoupling of buffered branches**

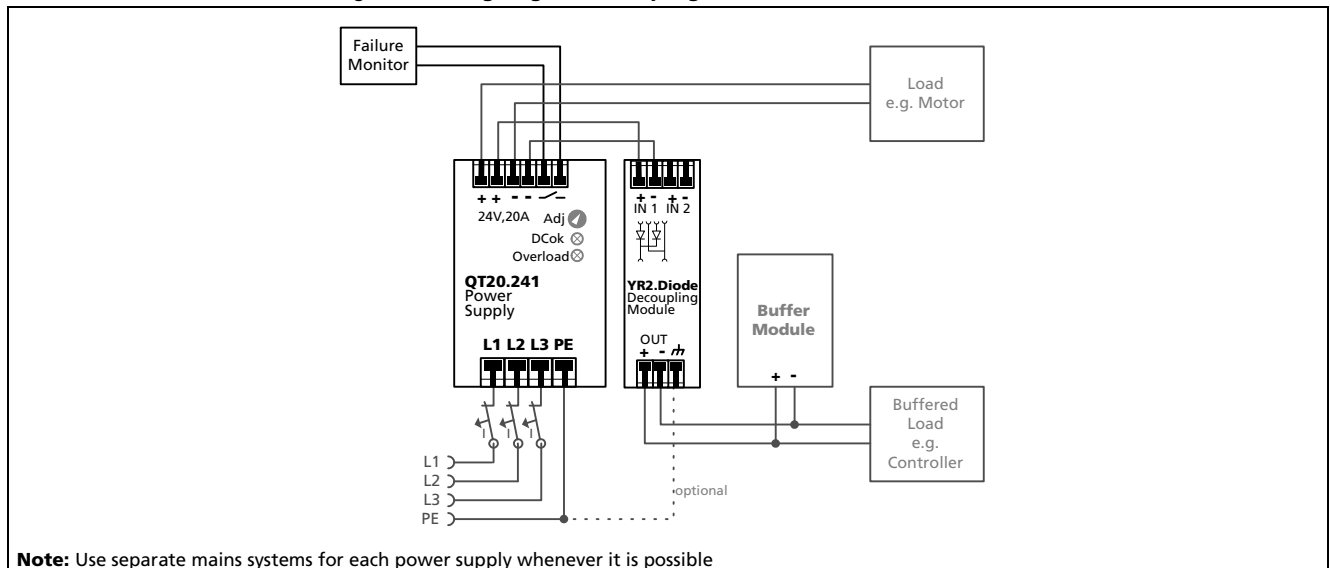

Note: Use separate mains systems for each power supply whenever it is possible

19.8. USE IN A TIGHTLY SEALED ENCLOSURE

When the redundancy module is installed in a tightly sealed enclosure, the temperature inside the enclosure will be higher than outside. The inside temperature defines the ambient temperature for the decoupling module.

Results from such an installation:

Power supply is placed in the middle of the box, no other heat producer inside the box

Enclosure:	Rittal Typ IP66 Box PK 9516 100, plastic, 110x180x165mm
Load:	24V, 16A; (=80%) load is placed outside the box
Input:	24Vdc
Temperature inside enclosure:	57.8°C (in the middle of the right side of the power supply with a distance of 2cm)
Temperature outside enclosure:	24.6°C
Temperature rise:	33.2K

19.9. MOUNTING ORIENTATIONS

Mounting orientations other than input terminals on the bottom and output on the top require a reduction in continuous output power or a limitation in the maximum allowed ambient temperature. The amount of reduction influences the lifetime expectancy of the power supply. Therefore, two different derating curves for continuous operation can be found below:

Curve A1

Recommended output current.

Curve A2

Max allowed output current (results in approximately half the lifetime expectancy of A1).

Fig. 19-6
Mounting Orientation A
(Standard orientation)

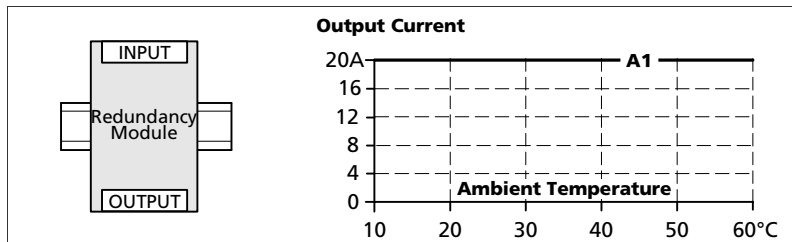

Fig. 19-7
Mounting Orientation B
(Upside down)

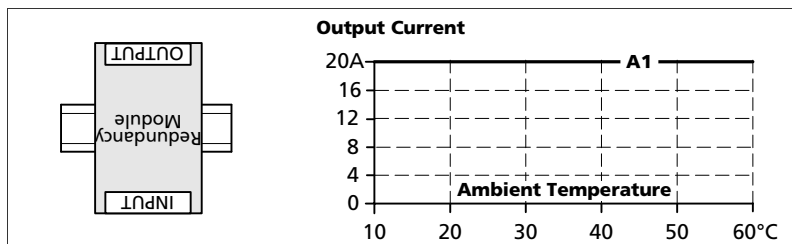

Fig. 19-8
Mounting Orientation C
(Table-top mounting)

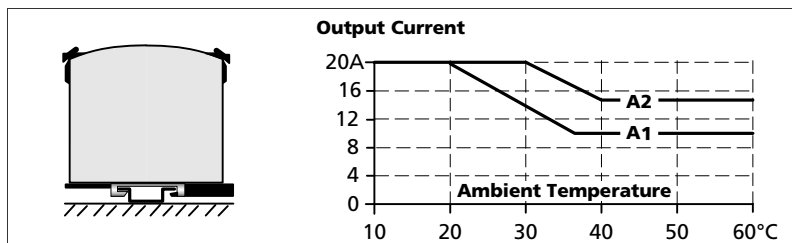

Fig. 19-9
Mounting Orientation D
(Horizontal cw)

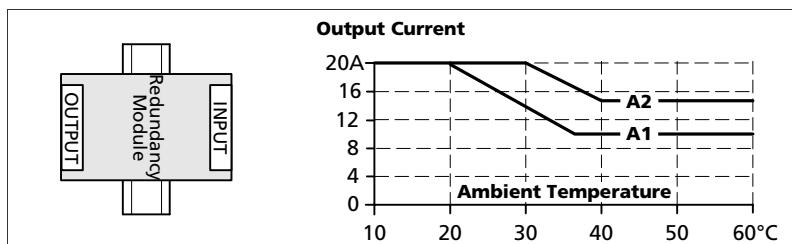

Fig. 19-10
Mounting Orientation E
(Horizontal ccw)

